

ASSEMBLY INSTRUCTIONS



Office Boffins

A-6PCS
M6*12mm



PRE-INSERTED

B-4PCS
M6*25mm



PRE-INSERTED

C-4PCS
M6*40mm



PRE-INSERTED

D-4PCS

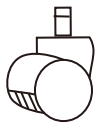

E-1PC

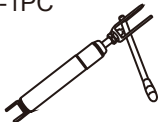

F-1PC

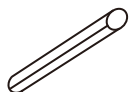

PRE-INSERTED

G-2PCS



PRE-INSERTED

H-4PCS



I-1PC



J-2PCS



WDNKN001

PLEASE NOTE:

The screws "A", "B" and "C" are pre-inserted into their correct holes to prevent them from being lost in transit. Please remove them before assembly using the allen key provided.

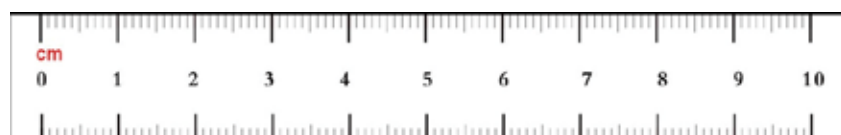

Do not tighten bolts fully until you have completed assembly.

DO NOT USE A POWER DRILL TO TIGHTEN THE SCREWS.

TIGHTEN BY HAND WITH THE ALLEN KEY PROVIDED.

1

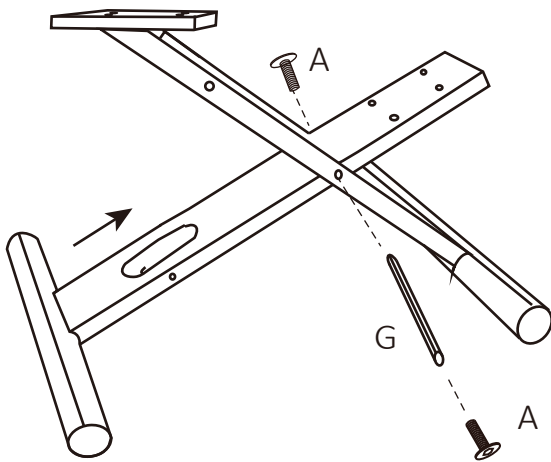

2

Place the gas lift (E) inside of the frame, on part closest to the seat, place pole (G) through the frame, washers (H) and gas lift (E) and loosely tighten bolts (A). On the lower part, place pole (F) through the frame, washers (H) and gas lift (E) and loosely tighten bolts (A).

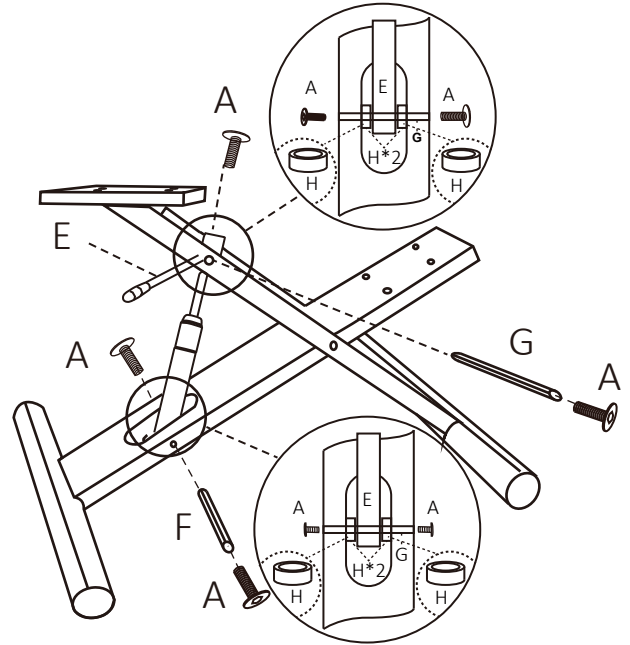

3

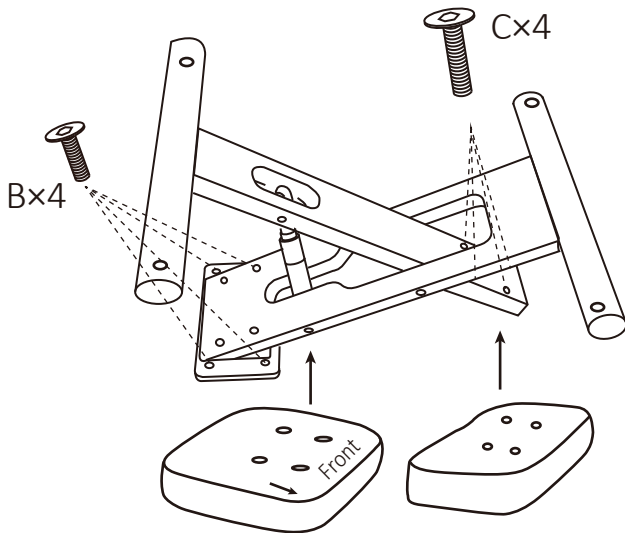

4

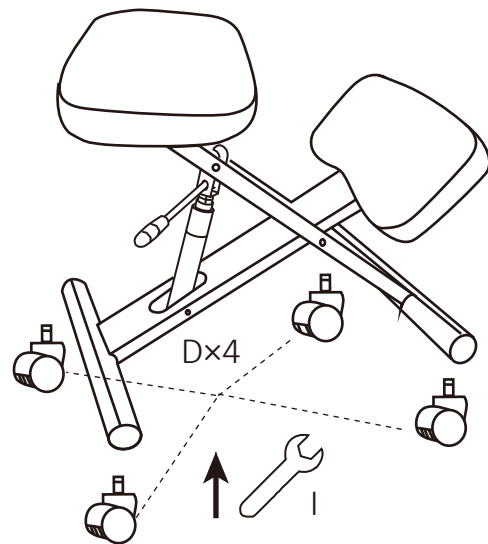

WARNING

- DO NOT STAND ON THIS CHAIR.
- DO NOT USE THIS CHAIR AS A STEP LADDER.
- USE THIS PRODUCT FOR SEATING ONE PERSON AT A TIME ONLY.
- DO NOT USE THIS CHAIR UNLESS ALL BOLTS, SCREWS AND KNOBS ARE FIRMLY SECURED.
- AT LEAST EVERY 6 MONTHS, CHECK ALL BOLTS, SCREWS AND KNOBS TO BE SURE THEY ARE TIGHT.
- IF PARTS ARE MISSING, BROKEN, DAMAGED OR WORN, STOP USING THIS PRODUCT UNTIL REPAIRS ARE MADE USING FACTORY AUTHORISED PARTS.
- FAILURE TO FOLLOW THESE WARNINGS COULD RESULT IN SERIOUS INJURY.